

PART I

1. FIGURE / GROUND AND REFERENCE FRAMES

The following presents the basic conceptual apparatus used in the linguistic description of static localization starting with the notions of Figure and Ground, and pursuing with classifications of systems of static localization.

I.1. FIGURE AND GROUND

The two most basic notions of the linguistics of space are *Figure* and *Ground*. These notions were introduced in Talmy (1972) to refer, respectively, to the located and to the locating entity. Other terms are also in use (*theme* vs *relatum* or *reference object*, *trajector* vs *landmark* ap. Langacker, *target* vs *landmark* ap. Vandeloise, *cible* / *site* in French) but *Figure* and *Ground* are the most common.

I.1.1. ORIGINS OF THE NOTIONS OF FIGURE AND GROUND

The Figure / Ground distinction was first introduced in psychology by the Danish psychologist Edgar Rubin and publicized in his 1915 study (Edgar Rubin, *Synsoplevede Figurer*, 1915, German trans. *Visuell Wahrgenommene Figuren*, 1921) probably inspired by French prints of the 18th (as pointed out by Gombrich 1978).

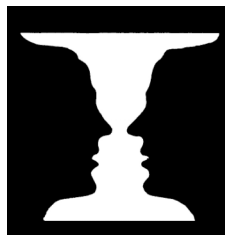

F and G were introduced by Talmy (1972 : 11) to refer to the located vs locating entity, perhaps inspired by Whorf.¹

Figure : “the object which is considered as moving or located with respect to another object.”

(1983 : 232 ; cf. also 1978) : “The Figure is a moving or conceptually moveable object whose site, path, or orientation is conceived as variable the particular value of which is the salient issue.”

Ground : “the object with respect to which a first is considered as moving or located.”

(1983 : 232) : “The Ground is a reference object (itself having a stationary setting within a reference frame) with respect to which the Figure’s site, path, or orientation receives characterization.”²

Ex. :

(1) *The bike_{Fig} is near the house_{Gr}.*

The second definitions of F and G imply that the subject matter of a locative question must be the Figure (since it is the Figure’s location that is at issue) :

(2) — *Where is the light?*

— *The light is next to the chair.* (not **The chair is next to the light*, except with a special intonation pattern: *the CHAIR is next to it*).

¹ “To compare ways in which different languages differently “segment” the same situation or experience, it is desirable to be able to analyze or “segment” the experience first in a way independent of any one language or linguistic stock, a way which will be the same for all observers. (...) There is one thing on which all observers of the appearance of a running boy will agree (...), that it can be divided into parts — and they will all make the division in the same way. They will all divide it into (1) a figure or outline having more or less of motion (the boy) and (2) some kind of background or field against which, or in which, the figure is seen” (Whorf 1956 [1939] : 162-3).

² These definitions depart from Rubin’s conception, for whom a Figure is thing-like and a ground is substance-like. For Talmy both F and G are thing-like.

In other words, this construction mirrors the F / G asymmetry.

Thus, the F / G asymmetry is naturally mapped to constructions which preserve this asymmetry :

(3) *The bike is near the house.*

(4) ? *The house is near the bike.* [the role assignment of this construction does not match the familiar world]

This asymmetry cannot be overridden by a construction which does not assign different roles to its arguments, i.e. a “symmetric construction” where both F and G are subjects (Talmy 1983 : 232) :

The bike and the house are near each other. [odd, according to Talmy, seems to convey that the house, is like a floating entity]

That is, even if the construction is “symmetric”, there is still an underlying asymmetry that manifests itself in the fact that the last sentence is slightly odd.

There are cases where F is not the subject and does not come first (Talmy 1978 : 420-1) :

(5) — *Where’s the pen?*

— *John has the pen.* [i.e. English lacks a construction like ‘the pen is at John’; note that in French or Russian such a construction exists but expresses possession, not location, and that in English *have* expresses possession too]

According to Talmy, such deviant cases reflect the lack of a proper construction (the language does not have a construction ‘F is at G’, or prohibits it, when G is an animate entity).

Cf. also :

(6) — *Where are my eyeglasses?*

— *You are wearing them!*

(in Talmy’s account, there is no notion that in certain contexts spatial localization is coexpressed with other aspects of the situation, like possession or routine activity etc. ; on the deep structure level, F comes first ; this problem will be tackled by Levinson et al. who will point out that the Basic Locative Construction ‘F is AT G’ surfaces when the situation at hand is stereotypically spatial, in a sense to be spelled out below ; on the semantics of adpositions, see part IV).

I.1.2. LOCALISM

The backdrop to Talmy’s introduction of the concepts of Figure and Ground is a *localist* theory of fundamental predicative structures. In Talmy (1972), Figure and Ground are elements of a skeletal universal syntactic-conceptual structure (akin to DS of generative semantics) comprised of 4 components : **F** (deep N) – **Motive** (deep V) – **Directional** (deep Prep) – **Ground** (deep N).

If F and G can be regarded as psychologically real, the perceptual status of Motive and Directional is unclear (are they perceptually segregated from entities?).

Talmy (1972) extends his skeletal F-M-D-G structure to non translatory situations, for ex. to causative situations : ex. *the soot fell into the creek from the wind blowing on it* and *the soot blew into the creek from the wind* are derived from [the soot_F fell_{FM} into_D the creek_G]_φ [followed]_ρ [from]_δ [the wind blowing on it]_γ (the extensions of F-M-D-G structure to non translatory situations are noted φ-ρ-δ-γ for Figurid-Relator-Director-Groundid).

F / G asymmetry is found in non spatial domains. For ex. *resemble* posits an asymmetrical relationship between a F and a G, in which the G is a standard of comparison :

(7) *My sister (F) resembles Madonna (G)*

(8) * *Madonna (F) resembles my sister (G)* (Talmy 1978 [2000] : 318).

Certain features of F and G can be transposed to the domain of temporal relations : an event contingent on another event is conceptualized as the F and temporally located with respect to the determinative event acting as G (Talmy 1978 [2000] : 324):

(9) *He dreamt while he slept.*

(10) * *he slept while he dreamt.* [the determinative G event “contains” the contingent F event]

I.1.3. DEFINITIONAL AND TYPICAL FEATURES OF FIGURE OF GROUND

Talmy (1978 [2000] : 315)

	Figure	Ground
Definitional characteristics	has unknown spatial (or temporal) properties to be determined	acts as a reference entity, having known properties that can characterize the Figure's unknowns
Associated characteristics	<ul style="list-style-type: none"> • more movable • smaller • geometrically simpler • more recently on the scene / in awareness • of greater concern / relevance • less immediately perceivable • more salient, once perceived 	<ul style="list-style-type: none"> • more permanently located • larger • geometrically more complex • more familiar, expected <ul style="list-style-type: none"> • of lesser concern / relevance • more immediately perceivable • more backgrounded, once Figure is perceived • more independent

I.1.4. COGNITIVE REFLEXES OF THE “TALMYAN” FEATURES OF F AND G

Early psycholinguistic experiments showed that some of these features have cognitive relevance. Subjects prefer to use *above* in describing the first configuration, and *below* for the second configuration (Clark, Carpenter & Just, 1973 : 332) : the smallest and more delimited entity is chosen as the Figure.



Cf. also McCarthy & Warrington, 1987 et 1990 : 293-4 for neuropsychological evidence : Patients with a short-term memory deficit must arrange the display so that the black block is above the white block. The task is performed with success if the theme is movable and is thus a “better” Figure than the other object. Instructions that correspond to good F and G in Talmy’s sense are less taxing for short-term memory.

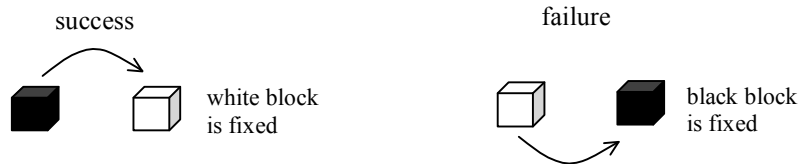

PART I

2. REFERENCE FRAMES

At issue here is the kind of spatial information that languages make use of in order to specify a Figure's location with respect to a Ground. The two main proposals emanate from Talmy and Levinson.

I.2.1. GEOMETRY AND REFERENCE OBJECTS : TALMY'S SYSTEM (TALMY 1983)

The focus is on English adpositions. Talmy distinguishes two broad kinds of information : the **geometrical and topological properties** encoded in adpositions, and the **directions** provided by Grounds (or "Reference Objects").

Regarding geometrical and topological properties, he argues that adpositions lexicalize **schemas** which abstract away from the concrete and detailed properties of referents. These "schemas are largely built up from some rudimentary spatial elements as points, bounded and unbounded lines, bounded and unbounded planes, and the like" (1983 : 258).

For ex. *across* : horizontal path-line running perpendicularly from one edge to the other of a planar object bounded by two opposite and parallel edges, with the edge-aligned dimension longer than the path-aligned dimension. The schema for *across the river* constitutes one instantiation of this very general schema (1983 : 260) :

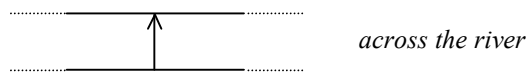

Across is indifferent to detailed shape, boundaries in the edge-aligned dimension (*across a river*), the medium (*across a river / a field*), and metric properties (*across the palm of my hands, across the country*).

More generally, Talmy argues that the closed-class elements of languages encode a limited range of conceptual categories (they do not encode detailed shape, absolute magnitude, color, precise number, seldom encode substance / medium and affect).

Characterizing location by one Reference Object :

(1) *The bike is near / in / behind the church.* [the church is **the primary RO**]

Of course, you must know where the church is in order to locate the bike, i.e. you must be able to relate the church to external bearings, but *near, in* or *behind* do not specify a direction with respect to bearings external to the church.

Characterizing location by more than one Reference Object :

- **encompassive secondary RO** : "One type of secondary Reference Object (...) encompasses the primary Reference Object ; i.e. its directional senses permeate – can be referred to throughout – the environment of the primary Ground" (1983 : 245-6).

Ex. :

(2) *John is ahead of Mary* (i.e., in a line) [the line is an encompassive secondary RO]

(3) *The bike is on the east side of the church* [cardinal directions are encompassive secondary RO]

(4) *The fly walked across the blackboard from right to left / *across the blackboard from bottom to top* [across makes a covert reference to the horizontal plane, the horizontal plane is a covert encompassive RO]

(5) *The egg is in the bowl sitting face up on the table / *The egg is in the overturned bowl* [in makes a covert reference to support from below, i.e. to a direction counter to gravity. This direction is an encompassive RO]

external secondary RO : Ex. :

(6) *The bike is on the cemetery side of the church* (i.e. on the side of the church [= primary RO] toward the cemetery [= secondary RO]).

“an external secondary Reference Object functions like a geometric point that singles out the particular portion of the primary Reference Object that is nearest to it, where this portion in turn serves to localize an adjacent Figure” (1983 : 250)

(7) *The bike is on this side of the church* (the secondary RO is a deictic centre).

Some secondary RO impart their own axes to primary RO : “**generation of an exterior reference frame by a secondary Reference Object**”, e.g. via *mirror-image reversal* (1983 : 253) :

(8) *The bike is to the right of the silo* [the secondary RO is a person, the framework generated is exactly like the encompassive type of secondary reference ; note that deixis is not considered as primary].

Finally, secondary ROs may be covertly present. Cf. the fact that, according to Talmy,

(9) **The egg is in the overturned bowl*

is unacceptable on the ground for the reason that *in* makes a covert reference to gravity³.

I.2.3. COINCIDENCE RELATIONS VS DIRECTIONAL INFORMATION : LEVINSON'S CLASSIFICATION

The basic distinction of Levinson is between two functional concepts : localization via (more or less approximate) coincidence / contiguity with a Ground vs localization via specifying directions from the Ground.

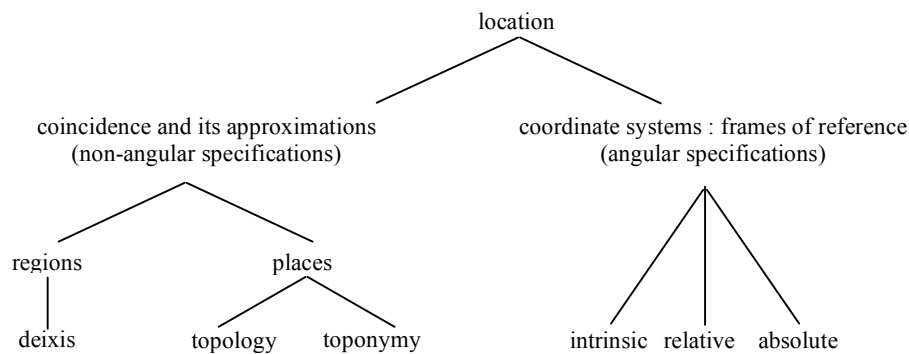

Topology is used in a rather informal sense here (basically, refers to AT, IN, ON, BETWEEN, NEXT TO, i.e. relations involving coincidence, enclosure, contact, order, proximity : after Piaget & Inhelder 1956).

The position of deixis exclusively under coincidence relations is potentially misleading since deixis is present in coordinate systems too : For ex., some markers require that the relatum of an absolute relation be deictically anchored (ex. bound morphemes ‘short distance from here uphill / downhill’ in Dyrirbal, Dixon 1972; cf. our lecture on deixis). What Levinson means is that deixis per se invokes coincidence and distance, not that deictically anchored relata are excluded from coordinate systems.

There is no implication that spatial expressions fall neatly into these conceptual divisions. For inst., *on* has a topological import (contact with an outer surface) and often makes reference to the gravitational (absolute) up-down axis (assuming that encoding a position on this axis is part of the meaning of *on* ; Taylor 1988). Talmy argues that *in* makes a covert reference to the gravity axis etc. In the same vein, many authors argue that the meaning of ‘in’ or ‘on’ cannot be described in exclusively topological or geometrical terms and makes reference to functional notions (for ex. the *control* of the position of F by G in the case of ‘in’ ; Vandeloise 1986). Finally, some adpositions are interpretable in more than one coordinate system (see below). These remarks should make clear that Levinson’s classification is about ways of conceptualizing spatial relations, and is not a semantic taxonomy of forms.

Toponymy will not be discussed here. Note, however, that it may be detailed to the point of obviating the need for other types of information (Levinson 2006 about Rossel islanders; Dixon 1972 : 57 observes that Dyrirbal has a wealth of place names, “for every bend in a river and dip in a ridge”).

³ However, Talmy’s account does not envisage a contrastive analysis of *in* (on this analysis, *in* is not acceptable because *under* wins out in this context).

(note : apparently, the notion of “reference frame” was introduced by the German Gestalt psychologist Karl Duncker (1929) in his experiments on “induced motion” [*induzierte Bewegung*], i.e. apparent motion of a spot of light induced by moving the background object functioning as its localizing “frame” [*Bezugssystem*], “illusion of the train passenger”).

I.2.4. TYPES OF FRAMES OF REFERENCE (Levinson 2003)

ABSOLUTE SYSTEM (BINARY OR TERNARY RELATION)

(10) *The ball is to the west (of the tree).*

Coordinates : absolute
Origin : west
Relatum / Ground : tree



Not necessarily ternary : *go north*.

However, absolute relations are often ternary (east / west are too vague) when it is a matter of localizing a Figure (and not of giving an orientation : *the man is facing west*). Note that it is not always possible to express the 3 terms of an absolute relation (this is impossible in Yéli Dnye, where absolute terms provide directions such as Eastwards or seawards ; cf. Levinson 2006).

In some languages, the absolute system is used for objects that stand a very short distance apart (e.g. a few centimeters away on a tabletop), and in some cases even for body parts (‘my eastern leg’, in Warlpiri, ap. Laughren 1978, or ‘lift you seaward foot!’ in Tidore, ap. Van Staden 2007).

INTRINSIC SYSTEM (BINARY RELATION)

(11) *The ball is to the right of the man.*

Coordinates : intrinsic
Origin : man
Relatum / Ground : man
Anchor point : right



The Figure lies in a **search domain** extending from the Ground on the basis of an angle or line projected from the centre of the Ground through an anchor point usually designated by a relator (*right of*). Some objects have inherent front, back and sides (e.g. a chair).

Note 1: Includes also : *The ball is in front of me*. “Whether the centre is deictic, i.e. whether the origin is speaker (or addressee) or not, is simply irrelevant to this classification” (Levinson 2003 : 38).

Note 2 : It is sometimes the case, especially in cultures which heavily rely on absolute frames, that left and right are used only intrinsically, and only for the L / R sides of the human body (for ex. in Tzeltal).

RELATIVE SYSTEM (TERNARY RELATION IN GENERAL ; SEE NOTE 3)

(12) *The ball is to the left of the tree.*



Coordinates : relative
Origin : viewer
Relatum / Ground : tree

The anchor points of the viewer may be mapped to the Ground, e.g. via **mirror reversal** (however, other ways of conferring a relative construal to intrinsic coordinates can be envisaged, as we shall see) :

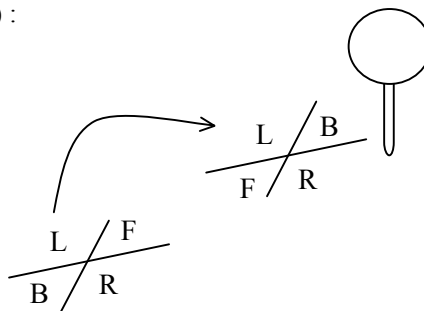

Note 1 : some cultures do not make use of this frame (Warrwa in McGregor 2006), or resort to them only marginally. If relative terms are used at all, they correspond to *front* and *back*, while *left* and *right* are left out and confined to the designation of body sides (Tzeltal ap. Brown 2006, Jaminjung ap. Schultze-Berndt 2006, Arrernte ap. Wilkins 2006).

The clearest illustrations of relative systems are provided with “unfeatured” Grounds, for ex. trees. However, not all languages agree on what may count as an unfeatured object (in Chamus, a tree has an inherent front, namely the side toward the tree is inclined or with the biggest branch or foliage ; Heine 1997 : 13).

Note 2 : Herskovits (1986 : 163) points out that there are mixed cases involving both a relative and an intrinsic frames. For ex. in *to the right of the road*, the road’s elongation axis is defined by the spine of the road (intrinsic) and the right and left sides are determined by the observer (she calls this situation *partly deictic*).

Note 3 : we should add expressions describing a Figure’s orientation with respect to a Ground, for ex. ‘facing’ or ‘looking at’ or ‘turning one’s back to’. In the case where *he is front of the tree* is interpreted as *he is facing the tree*, a temporary front is projected onto an “unfeatured” G. This projection seems to be available only when the Figure is human-like or animate (does not work for a chair, a car, a computer or a gun, which have inherent fronts yet fail to project it onto the Ground when they face it ; *the chair is in front the tree ≠ the chair is facing the tree*).

REMARKS

This classification does away with the traditional primacy of the egocentric viewpoint (found, for ex., in Clark 1973) : even if egocentricity or viewer-centered representations are cognitively primary, this does not mean that egocentric coordinates predominate in all languages.

The primacy of egocentricity is based on the argument that the human body is the first frame of reference and that other relations are determined with respect to this frame. Cf. Kant (1991 [1768] : 28-29) :

“Since through the senses we know what is outside us only in so far as it stands in relation to ourselves, it is not surprising that we find in the relation of these intersecting planes to our body the first ground from which to derive the concept of regions. The plane to which the length of our body stands perpendicular is called, in reference to us, horizontal ; it gives rise to the distinction of the regions we indicate by *above* and *below*. Two other planes, also intersecting at right angles, can stand perpendicular to this horizontal plane, in such manner that the length of the human body is conceived as lying in the line of their intersection. One of these vertical planes divides the body into two outwardly similar parts and supplies the ground for the distinction between right and left ; the other, which is perpendicular to it, makes it possible for us to have the concept of *before* and *behind*. (...) Even our judgments about the cosmic regions are subordinated to the concept we have of regions in general, in so far as they are determined in relations to the sides of the body. All other relations that we may

recognise, in heaven and on earth, independently of this fundamental conception, are only positions of objects relatively to one another.”⁴

The terms “absolute” and “relative” go back to the Newton – Leibniz controversy on the nature of space. “Intrinsic” might come from Clark (1973).

I.2.5. THE PROPERTIES OF FRAMES: A COMPARISON

Intrinsic frames

Inferential potential (Levelt 1996) : an intrinsic frame has a weak inferential potential :

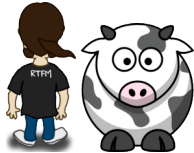

- Converseness does not hold : *The cow is to the right of the man does not imply that the man is to the left of the cow.*



- Transitivity : *the zebra is to the right of the man and the man is to the right of the cow do not imply that the zebra is to the right of the cow.*

- Intrinsic terms may induce confusions with relative frames (left is interpretable intrinsically or relatively).
- Left and right are sometimes undetermined (what is the right or the left of a stadium?).

Relative frames

- mapping of relative anchor points to a relatum (cf. *mirror reversal* above) may cause ambiguities (in fact, relative systems often evolve from intrinsic ones, esp. from body part terms, and share lexical resources with them, hence the ambiguities).

Absolute frames

- some absolute terms may refer to global fixed bearings or to local bearings (cf. *west* above).
- some absolute terms may take on a relative meaning (e.g. *uphill* = ‘higher in my field of vision’ ; Levinson 1996, 2003).
- absolute terms are sometimes used for identifying intrinsic facets of an object (cf. the *west* wing of a castle).

Constancy under rotation (Levinson 2003)

	Rotation of viewer Same description ?	Rotation of Ground Same description ?	Rotation of whole array Same description ?
Intrinsic : ball in front of chair	yes	no	yes
Relative : ball to the left of chair	no	yes	no
Absolute : ball to the north of chair	yes	yes	no

⁴ “Da wir alles, was außer uns ist, durch die Sinne nur in so fern kennen, als es in Beziehung auf uns selbst steht, so ist es kein Wunder, daß wir von dem Verhältnis dieser Durchschnittsflächen zu unserem Körper den ersten Grund, den Begriff der Gegenständen im Raume zu erzeugen. Die Fläche, worauf die Länge unseres Körpers senkrecht steht, heißt in Ansehung unser horizontal ; und diese Horizontalfläche giebt Anlaß zu dem Unterschiede der Gegenden, die wir durch Oben und Unten bezeichnen. Auf dieser Fläche können zwei andere senkrecht stehen und sich zugleich rechtwinklicht durchkreuzen, so daß die Länge des menschlichen Körpers in der Linie des Durchschnitts gedacht wird. Die eine dieser Verticalflächen theilt den Körper in zwei äußerlich ähnliche Hälften und giebt den Grund des Unterschieds der rechten und linken Seite ab, die andere, welche auf ihr perpendicular steht, macht, daß wir den Begriff der vorderen und hinteren Seiten haben können” (1968 [1768]).

- In an intrinsic frame F and G form a higher level array that can be rotated in space.
- In a relative frame the F and the Origin can be rotated around the G.
- In an absolute frame F and G can (independently) rotate on themselves.

These properties will be exploited in a series of experiments on the cognitive correlates of linguistic frames (in particular, how does rotation of viewer affect recall of a stimulus array? Is the array recalled the same in terms of relative coordinates, or is it the same in terms of absolute coordinates? Does the linguistic predominant coding determine the way an array is recalled?).

Intertranslatability of frames

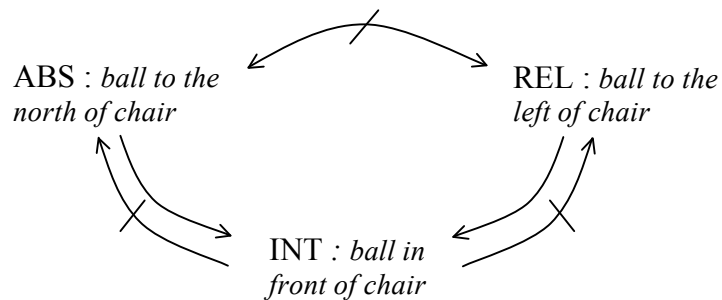

Suppose the location of the ball with respect to the chair is given to you in absolute, relative or intrinsic terms and that you can correctly identify these bearings. On the basis of the information given to you, can you rephrase the description of the ball's location using another frame?

Levinson (2003) reasons that:

To communicate about space you need to register spatial coordinates

Some coordinate systems are not intertranslatable (if you fail to register absolute coordinates, you cannot recover them from relative coordinates, and conversely)

Therefore you must register spatial coordinates in the frame of ref. of your own language.

In other words, for Levinson, the limited intertranslatability of frames is an argument in favour of linguistic relativism.

AN EXAMPLE



Examples of absolute frames :

Tzeltal : Man is downhillwards (= North), tree standing uphillwards, he is looking uphillwards.

Arrernte : Man standing on the west-side, tree in eastern region, he is facing toward the tree.

Yéli Dnye : Tree standing seawards, man approaching tree.

Note that there are 2 pieces of information to convey (Levinson & Wilkins 2006 : 545s) :

- (1) which side is the tree and which side the man ;
- (2) the orientation of the man with respect to the tree.

Tzeltal does not code the orientation of the man with respect to the tree (the man's line of sight could bypass the tree). The 'facing an absolute direction pattern' is also found in Arrernte and Yéli Dnye, with the consequence that the orientation of F w/r to G may not be explicitly stated.

Note the absence of a relative frame (although it exists marginally in Tzeltal, Arrernte and Yéli Dnye).

In English (German, French, Japanese...) information (1) is typically given in relative terms (tree on the left, man on the right) and information (2) in intrinsic terms (man facing the tree).

I.2.6. LANDMARKS

Distinct from intrinsic systems (do not identify sides via directions, functions, shapes of parts etc.). Distinct from relative systems (description does not change under rotation of viewer). However, a landmark system is similar to a relative system in the sense that it is ternary when it provides directions, e.g. *The bike is on the cemetery side of the church* (see Talmy).

Can be functionally equivalent to an intrinsic system (cf. *enter the building from Oxford Street*, where a side is identified via a landmark) or an absolute one, binary (*when you leave Paris, take the direction of Lille* = drive North), or ternary (*The bike is on the cemetery side of the church*).

Levinson considers that landmark systems as in ‘the man is mountain-wards of the tree’ are “giant” intrinsic systems, apparently because a side of the tree is identified as mountain-ward and the man is located with respect to this side ; however, the relation is ternary (man, tree, mountain), and the relation of landmarks to absolute systems is obvious (you need to compute the axis that joins the tree to a possibly far mountain).

I.2.7. TALMY’S AND LEVINSON’S ANALYSES COMPARED

Both Levinson and Talmy make a distinction between binary and ternary systems and both do away with the traditional privilege of egocentricity.

Unlike Levinson, Talmy does not separate neatly topological relations from other (intrinsic) binary relations (both involve only a primary RO).

Talmy’s analysis makes it easy to describe landmark systems (they are systems with external secondary RO) and partly deictic situations (*to the right of the road* : the primary RO defines the main axis and an external secondary RO, viz. the observer, defines the front / back direction and the L / R axis).

Talmy’s discussion of systems with encompassive ROs does not distinguish scales : a line in which people are queuing up and cardinal directions are all encompassive ROs. On the other hand, in Levinson’s account, the case of *John is ahead of Mary (in the line)* is unclear : the front of the line is defined intrinsically but the relation between John, Mary and the line is ternary.

Talmy points out similarities between landmark systems, absolute frames and relative frames (they are ternary and invoke secondary ROs, and some absolute systems do function with landmarks, e.g. volcanoes in Bali).

In Talmy’s account, secondary ROs may be covertly present in intrinsic reference (ex. cf. the fact that **The egg is in the overturned bowl* is unacceptable on the ground that *in* makes a covert reference to gravity⁵). This highlights the fact that the classification of linguistic markers does not coincide with coordinate systems.

However, Levinson’s classification, by assigning absolute systems, esp. systems with general directions, to a special class (in Talmy’s terms, systems with encompassive ROs that permeate a vast territory) singles out a type of frame that is remarkably important in some non Indo-European languages. In the same vein, relative frames are a useful category because the presence / absence of relative coordinates is a feature that differentiates linguistic systems. Thus, Levinson’s classification is centered on core, salient cases which bring out major crosslinguistic differences. It is less abstract than Talmy’s, concerns closed class lexical items (not landmarks), and is now widely adopted.

⁵ However, Talmy’s account does not envisage a contrastive analysis of *in* (in this analysis, *in* is not acceptable because *under* wins out in this context).

I.3. ABSOLUTE, INTRINSIC AND RELATIVE FRAMES

The following sections provide examples of absolute, intrinsic and relative frames and illustrate their functioning.

I.3.1. ABSOLUTE FRAMES – LANDMARK SYSTEMS

I.3.1.1. CARDINAL POINTS

Arernte (Australia, Pama-Nyungan, Arandic ; Wilkins 2006 : 56)

(speaker facing south)

(13) *artwe nhenhe re alturle-thayte-le anteme tne-rle.ne-me, arne*
 man this 3SG.NOM west-side-LOC now stand-CONT-npp, tree

ikwere-werne-theke anteme, arne re kenhe ikngerre-ampinye-le anteme.
 3sgDAT-ALL-wards now, tree 3SG.NOM but east-vicinity-LOC now

‘The man here is now standing on the west side, (facing) towards the tree now, but the tree is now in the eastern region.’

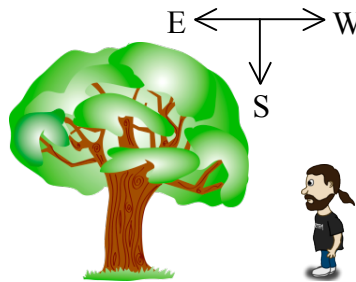

Cardinal directions are even used in the formation of verbs (with an inchoative meaning indicating a change of direction ; ibid. : 59) :

(14) *ayerrere-werne-theke alh-ø-aye ! Kele anteme ikngerre-theke-irre-ø.*
 North-ALL-wards go-IMP-EMPH ok now east-wards-INCH-IMP
 ‘Go northwards. Ok, now turn east.’

I.3.1.2. DIRECTION OF WATER FLOW : UPSTREAM / DOWNSTREAM

Jaminjung (Australia, Jamingungan / Yirran ; Schultze-Berndt 2006 : 67 ; if stative, *manamba* ‘upstream’ is unmarked, i.e. does not take a spatial case like *ngining* ; often unmarked too when indicating a goal).

(15) *pigipigi mung ga-yu yina-wurla-ngining, manamba-ngining.*
 pig look-at 3SG-BE.PRS DIST-DIR-ALL upstream-ALL

‘A pig is looking that way, upstream.’ [*mung* ‘look at’ is analyzed as a coverb]

I.3.1.3. INLAND-SEAWARD AND WATERSHED

Inland-seaward directions are commonly found in Austronesian cultures.

Taba (Indonesia ; Austronesian, Eastern Malayo-Polynesian ; Bowden 1997) : deictic directionals combine with absolute directions and locate Figures in Regions projected from the Ground when there is no contact between the Figure and the Ground (an intrinsic part cannot be extended to a region).

	<i>ya</i> ‘up’	<i>po</i> ‘down’	<i>la</i> ‘sea’	<i>le</i> ‘land’	<i>no</i> ‘there’
ESSive	<i>yase</i>	<i>pope</i>	<i>lawe</i>	<i>lewe</i>	<i>noge</i>
ALLative	<i>attia</i>	<i>appo</i>	<i>akla</i>	<i>akle</i>	<i>akno</i>
VENitive	<i>yama</i>	<i>poma</i>	<i>lama</i>	<i>lema</i>	<i>noma</i>

(16) *tabako a-dia kurusi ni lae lama.*
 cigarette DEM-DIST chair POSS lawe lama

‘The cigarettes are there, in the seaside space here w/r to the chair.’ [for inst. on the right side of the chair if the sea is to the right] (Bowden 1997 : 260)

Mwotlap (Vanuatu, Austronesian ; François 2003). No use of L / R, and little use of intrinsic / relative frames. Double system : an inland-seaward opposition, and a (roughly) east-west axis, aligned on a ridge separating rivers. Directionals (hither, thither, up, down), personal deixis and topological items override absolute coordinates, which serve as a default strategy, e.g. when motion is in a direction where no salient participant is present.

(17) *suwyeg nê-bê hay anen.*
 AO.throw.away ART-water inland DX2
 ‘Just throw the water there [close to you (*anen*), inland side].’

(18) *no-totgalmey lok yow.*
 ART-picture REL again seaward
 ‘The picture seaward.’ (ibid. : 423) (said when a photo album was being held vertically ; when held horizontally, speakers used *up* and *down*)

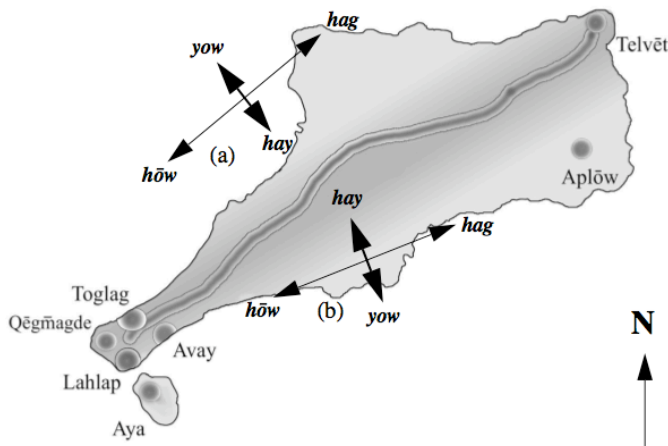

The divide which runs approximately from east to west is at times invisible and is therefore an abstract line that must be learned conventionally.

How / hag also mean down /up. The *how / hag* axis points south-east when the island is out of sight (when at sea) This axis corresponds to the direction of trade winds, which blow from the southeast. *Hag* is therefore to navigate against the wind, hence the directional meaning of ‘up’ (cf. English upwind).

I.3.1.4. MOUNTAIN > CARDINAL POINTS

Bali (Wassmann & Dasen 1998) : remarkable case in which fixed bearings (like east and west) are variable across a region, because they are secondary to a prominent, *environment*-bound axis (Mount Gunung Agung and local peaks) and are sometimes derived from a locality from which inhabitants originated. Ex. (Wassmann & Dasen 1998 : 698, considerably simplified) :

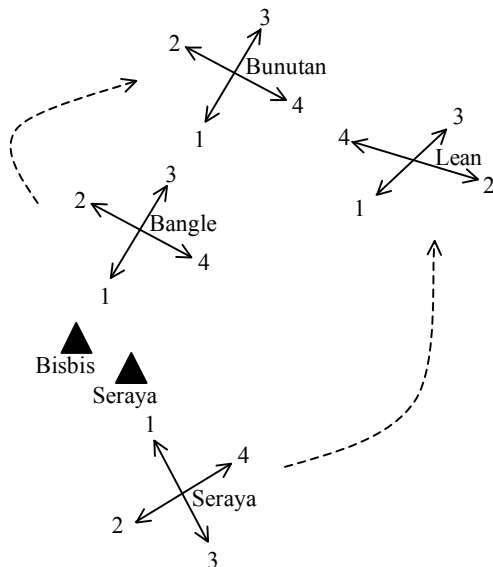

- 1 : *kaja* (towards mountain)
- 2 : *kauh* (west)
- 3 : *kelod* (towards sea)
- 4 : *kangin* (east)

Bunutan was populated from Bangle and Lean from Seraya (dotted arrows).

The cultural importance of the mountain-sea axis is further attested by symbolic associations :

kaja	village temple	family temple	direction of head during sleep	Wisnu	black
kelod	cemetery	kitchen, rubbish, animals	direction of feet during sleep	Brahma	red

Widespread use of absolute coordinates. Speakers make little use of L/R for spatial orientation. Ex. : “Please pass me the dish which is *kaja*.”

I.3.1.5. UPHILL / DOWNHILL

Tzeltal (Brown 2006)

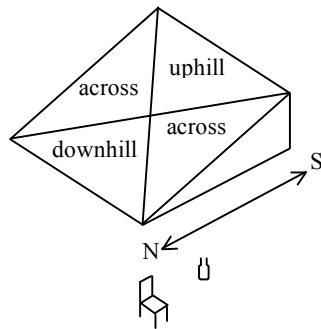

‘The bottle is uphill from the chair.’

The uphill / downhill axis has been internalized as a general direction and is applicable even on the horizontal, sometimes miles away from the speakers’ village. It does not extend to body space (one does not refer to a person’s “uphill” arm, for inst.). It is used when F and G are widely separated (otherwise body-part and relational locatives are employed). The orthogonal direction (*jejch* ‘across’) is specified gesturally or w/r to a salient landmark and / or the direction of sunset and sunrise.

(19) *ay-ø ta y-qik’ol te’ te limete.*
 EXIST-3A PREP 3E-uphill tree ART bottle
 ‘The bottle is to the uphill of the tree.’

Possessed adjectivized forms of *uphill / downhill* furnish equivalents of ‘above’ / ‘below’ and serve to locate objects on the *vertical* axis.

Uphill / downhill may also be used in local environments, where they correspond to the local inclination of the terrain (which might differ from the global N/S axis). There are (marginal) relative uses of *uphill / downhill*, only in elicited tasks (i.e. uphill = ‘higher in my / your field of vision’ and downhill = ‘lower’).

I.3.1.6. URBAN FRAME

Downtown / out of town provide absolute directions which vary with the location of the Ground, like in *downtown from here* (parallel to a landward / seaward system and different from a system using cardinal directions or directions abstracted from environmental features and invariant over a large expanse of territory, like *uphill / downhill* in Tzeltal).

I.3.1.7. VERY LOCAL ABSOLUTE FRAMES

Pseudo-absolute or ad hoc frame (Bohnenmeyer & Stolz 2006).

We can say (equivalently) that an animate body sets up a very local up-down axis or that it has an intrinsic top (suppose a family of ticks live on a dog and call its head *north* and the tip of its tail *south*). A chair cannot provide a very local axis.



(20) *A butterfly landed above the baby’s nose.*

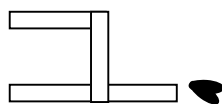

(21) *#A butterfly landed above the chair.*

I.3.1.8. “ABSOLUTE” TERMS ANCHORED ON LANDMARKS

For historical and cultural reasons directions to some landmarks may be coded with absolute terms. For inst. in Tidore 'upward' may mean 'in the direction of the Sultan's palace'. In this cases, a semantically absolute terms functions as a goal marker conventionally associated with a landmark (for an intricate system).

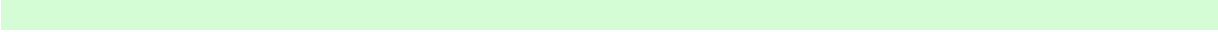

I.3.2. INTRINSIC FRAMES

This section deals with those spatial nouns (names of objects' parts) which have a localizing function. The case of topological-functional simple adpositions is deferred to another lecture (part IV.2).

I.3.2.1. SPATIAL NOMINALS

In an intrinsic frame, the G's parts with respect to which a F is located are typically designated by **spatial nominals (spatial nominals ap. Levinson ; also: relational nouns)**. A part which assumes this function is a **spatial part**.

Ex. : *front, back, side, top, bottom, corner, mouth, edge, tip* etc.

Not all spatial nominals identify a part by localizing it : an *angle* or a *corner* do not have fixed localizations, rather, they identify shapes (cf. *infra* "armatures").

Levinson et al. (2003) : "spatial nominals".

In Japanese (and Korean), a typical template for the Basic Locative Construction is [Ground-GEN Spatial_Nominal-PostP] (see Kita 2006 for details on its range of application).

(22) *ringo wa booru-no naka-ni a-ru.*
apple TOP bowl-GEN interior-DAT be-PRES

[lit.] 'the apple is at the interior of the bowl' i.e. 'the apple is in the bowl.'

Ewe (Ameka & Essegbey 2006 : 371)

(23) *Kɔpu lá le kplɔ̃-a dɛ́.*
Cup DEF be_at.PRES table-DEF upper surface

[lit.] 'The cup is located at the table's upper surface' i.e. 'the cup is on the table.'

Tzeltal (Brown 1994)

(24) *ta x-chikin mexa.*
PREP 3E-ear table

'at the corner of the table.'

In the French literature, following Aurnague (1996) spatial nouns are usually called "**nouns of internal localization**" : "they carve out parts which occupy fixed positions in the whole entity" (ibid. : 165). In Basque, NIL take a locative genitive case :

(25) ?? *mahaiko zangoa.*
table-GEN.LOC leg

'The leg of the table.'

(26) *mahaiaren zangoa.*
table-GEN leg.

'The leg of the table.'

(27) *mahaiaren atzineko zangoa.*
table-GEN front.GEN.LOC leg.

'The leg of the front of the table.'

NLI have a lesser degree of "referential autonomy" : **c'est un fond* 'it's a bottom' vs *c'est une roue* 'it's a wheel'.

According to Aurnague, French NIL license *à* but other meronyms do not :

(28) **L'étiquette est au manche du couteau.*

[lit.] 'The tag is at the knife's handle.'

(29) *L'étiquette est au pied de la table.*

[lit.] 'The tag is at the table's leg.'

In French, NIL and "non-bleached" prepositions "locativize" objects which are not "locative" enough to occur after *à* or *de*, or which can occur after *à / de* in very restricted conditions :

(30) ? *Il est à l'arbre.*

'He is at the tree.' [*tree* is not locative enough, or needs a specific context, for inst. one in which *tree* is interpreted as a milestone along the path of a moving Figure]

With an NIL :

(31) *Il au pied de l'arbre.*
 'He is at the foot of the tree.'

With a “non-bleached” preposition :

(32) *Il est devant l'arbre.*
 'He is in front of the tree.'

Korean spatial nouns apparently fulfill the same function in the context of motion V: they function as “locativizers” of nouns that otherwise could not be construed as locations (Choi-Jonin & Sarda 2007 : 135) :

(33) **kəul-e ga-sə məri mancjə po-go.*
 mirror-LOC go-CS hair arrange-CS
 'He goes to the mirror to do his hair.'

(34) *kəul-ap^h-e ga-sə məri mancjə po-go.*
 mirror-front-LOC go-CS hair arrange-CS
 'He goes in front of the mirror to do his hair.'

Since they also identify regions projected from the part they name, spatial nouns are often ambiguous :

(35) *Le devant de la maison est sale.*
 'The front of the house is dirty.' [part or region ?] [more on this in the lecture on diachrony, part V]

Confusions between parts (contact) and regions (non contact) are therefore frequent. For ex., Japanese does not distinguish ‘on’ and ‘above’ (Kita 2006 : 447) :

(36) *teeburu-no ue-no rampu.*
 table-GEN top-GEN lamp
 'The lamp is on / above the table.' [lit. 'the lamp of the top of the table']

When the F is in relation to a part, not to a region, the relation is **internal**. Otherwise, the relation is **external** :

(37) *La lampe est au coin du tapis.*
 [lit.] 'The lamp is at the corner of the rug.' [internal or external relation ?]

However, these ambiguities are context-sensitive. E.g. *en haut de l'armoire* ('on top of the cupboard') is external or internal, whereas *en bas de l'armoire* '[lit.] at the bottom of the cupboard' is preferentially internal.

There are cross-linguistic differences : Basque seems to favor external interpretations more often than French (this is the case with the Basque equivalent of ‘bottom’). Disambiguation for ex. with ‘sur’ : *la lampe est sur le haut de l'armoire* ('the lamp is on the top of the cupboard') vs *au haut de l'armoire* (external or internal?) ; but *sur* is not watertight (cf. *la lampe est sur le bord du tapis* : contact but internal or external?). There are also spatial nouns which refer unambiguously to parts vs regions : *gauche / droite* ('left' / 'right') in *à (la) gauche de / à (la) droite de* > external interpretation ; *avant / arrière* ('front' / 'back') are internal in *à l'avant de / à l'arrière* (= 'in the front / back of').

I.3.2.2. CONCEPTUAL SYSTEMS OF SPATIAL PARTS : “ARMATURES”

The spatial nominals we have encountered so far are obviously diverse : interior (< topology), upper surface (< shape + absolute orientation), ear (< shape, cf. Tzeltal sentence above), top (< absolute localization). Can we put order in this diversity?

Levinson (2003) proposes a three-way classification of systems of partitioning (“armatures” in his own terminology) : fixed armature / armature based on the shape of parts / functional armature, to which I add kinetic armature.

Fixed armature : spatial nouns identify parts and regions which correspond to locations in a wider frame (relative or absolute). Ex : Zapotec (MacLaury 1989, Levinson 2003).

Zapotec comes close to a system with an exclusively fixed armature : the human frame is mapped to objects, parts change names if they change position. For inst., the ‘back’ of a hanging mat becomes its ‘bottom’ if the mat is laid flat on what was its ‘back’; the nearest side (bank) of a river is its *face* and its further side is its *back* ; MacLaury 1989 : 129, 143).

There are a few exceptions to this part / location correspondence. 3 spatial nouns apply to parts with distinctive shapes : *roʔo* ‘lip’, which names an opening or a ridge, a strip-like edge, for example the rim of a mat, and does not change name when it changes position ; *lō* the ‘face’ of the table below, which applies to flat surfaces and abstract location, e.g. abstract containment in *in that starvation, he died*; *laʔayn* ‘stomach’, which designates 3-dimensional or contained locations.

The human frame is mapped to the space surrounding an object, and the corresponding body part names designate regions (‘head table’ = ‘over the table’ ; note that the region projected from the table and which is named ‘face’ does not correspond to the part of the table which is named ‘face’).

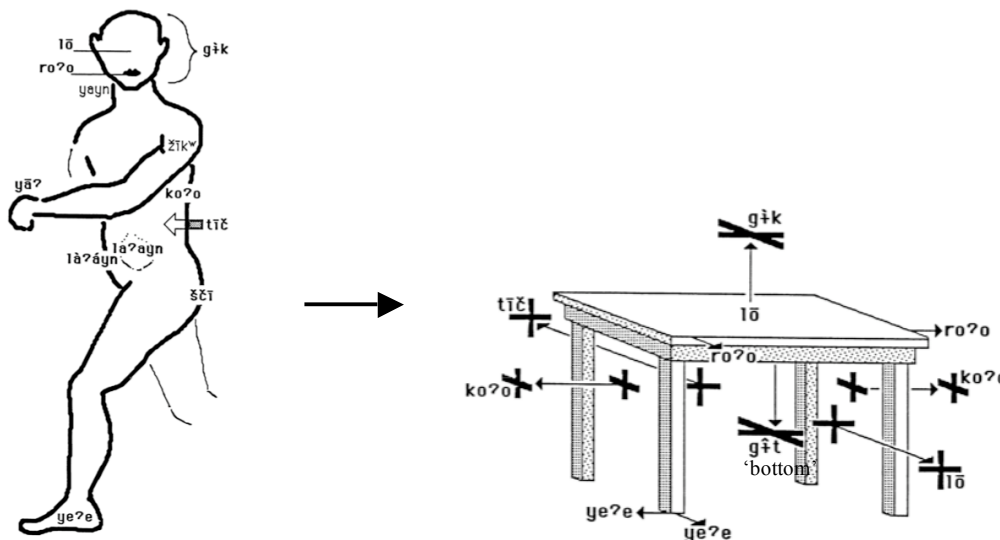

Armature based on shape : spatial nouns identify parts of a certain shape. In Tzeltal a coffee pot has a ‘nose’ (its spout), a ‘mouth’ (the rim of the opening), an ‘ear’ (the handle)... Spatial nouns are assigned as a function of their axial and volumetric geometry.

According to Levinson (1994) the Tzeltal system implies that spatial nouns are mapped to an object’s parts as a function of their convexity / concavity, degree of protrusion, texture, sharpness, symmetry :

A protrusion of sharp convexity is a ‘nose’. A smaller protuberance is an ‘eye’. A long protrusion is a ‘lower leg’, a thin one a ‘tail’ (for ex. an electric cord). The less textured side of a leaf is its ‘face’. An object with a wide conic section has a ‘belly’ (for inst. a glass or a gourd). Sharp edges are ‘teeth’.

Symmetry : the axis yielding two symmetrical halves is the secondary axis and its flat part is its back (thus, the flat part of a stool is its ‘back’, the flat edge of a knife is its ‘back’).

There is an apparently marginal intrusion of deixis : some speakers tend to call a flat opposite surface the ‘face’.

Functional armature : spatial nouns identify parts of a certain function (e.g. the front of a building is the side where you enter, or the side overlooking the street, the front of a computer is the side with the screen ; for a number of objects, the front part corresponds to the “interactional” side). In English, functional parts are identified once and for all (unlike in Zapotec, but like in Tzeltal), otherwise we are dealing with a fixed armature, and the names of spatial parts, like *front*, *back*, *top* and *bottom* are typically derived from their canonical orientation (unlike in Tzeltal).

Kinetic armature : the front is the side that comes first in the direction of movement. As for tops and bottoms, “kinetic” fronts are intrinsic w/r to the side that is canonically facing the direction of movement (for ex. the front of a car remains its front even if the car is moving backward).

1.3.2.3. TYPES OF LEXICALIZATION

Framed parts <=> Intrinsic parts : case in which a noun which designates a part identified by its current position in a wider frame (relative or absolute) can be used for an intrinsic part, and vice versa, e.g.

Front (of car) / front side of a cube, i.e. the front side as determined in a relative frame.

Top (of table) / top side of a cube, i.e. the upper side as determined by absolute verticality.

Intrinsic parts ≠> framed parts : case in which a spatial noun always identifies the same part, regardless of the object's orientation. Ex. : Tzeltal (with the exception of deictic uses).

Framed parts ≠> Intrinsic parts : case in which a meronym identifies a part with respect to a frame and changes reference if the object's orientation changes. Ex. : Zapotec.

Parts => regions : case in which the meaning of a spatial meronym can be extended to the region identified by a local part. Ex. : *front* and *back* in English.

Parts ≠> regions : case in which the meaning of a spatial meronym cannot be extended to a region. Ex : left and right in Tzeltal

In English, *front* stands for an intrinsic part, a framed part and a region.

I.3.2.4. ASSIGNING INTRINSIC PARTS IN ENGLISH

Entities with a perceptual apparatus : man, doll, camera (front contains perceptual apparatus, L and R are assigned as for a human body ; the relevance of this feature was first pointed out by Fillmore 1971)

"Body envelopes" : vehicles, seats and clothes (chairs, shirts, pants ; noted by Miller & Johnson Laird 1976 : 401).

Faced entities : Interactional objects (pianos, TV sets, computers) (noted by Bierwisch 1967 ; Vandeloise 1986 : 51 : anthropomorphic orientation).

Kinetic entities : French *avant* / *arrière* compete with *devant* / *derrière* (also with objects built on a "launching" axis : guns, rifles ; noted by Teller 1969).

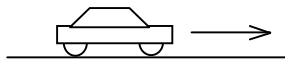

Capitalizing on the studies of Bierwisch, Teller and Fillmore, Miller & Johnson Laird (1976 : 403) proposed the following flow chart for the assignment of intrinsic parts :

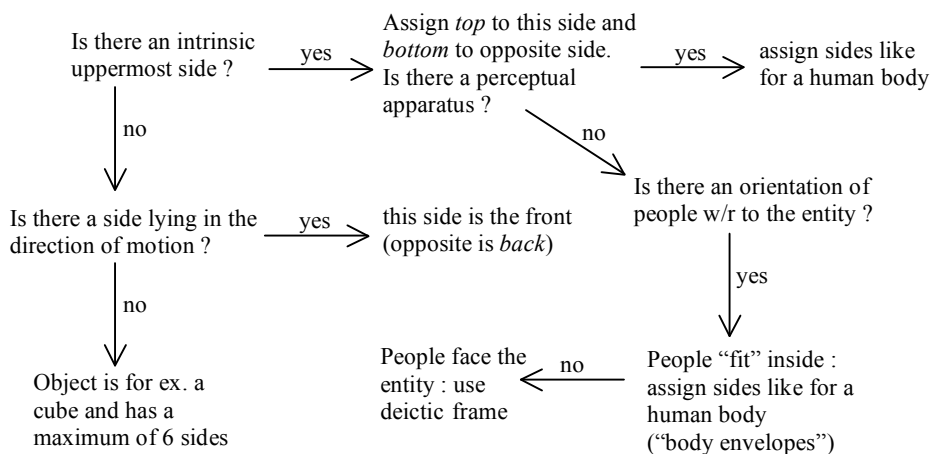

I.3.2.5. FROM INTRINSIC PARTS TO FRAMED PARTS TO REGIONS

One way to distinguish intrinsic parts from framed parts is to designate parts by nominals which have a greater degree of "nouniness" than their counterpart spatial nominals in more grammaticalized adnominals. That is, entities which are more individuated are designated by lexemes that are more syntactically autonomous.

Cf. for ex. Talmy (1983 : 247) : *there is a fly on the top of the TV* (the top of the TV refers to the side above the screen, whatever the orientation of the TV may be > intrinsic part).

vs

there is a fly on top of the TV (the fly is on the uppermost side of the TV given the TV's current position > framed part).⁶

Cf. French : *il y a une mouche sur le (côté droit du) dessus de la télé / au (*côté droit du) dessus de la télé* (“le dessus” in *sur le dessus* is more autonomous and the part is intrinsic ; “le dessus” in *au-dessus* is less autonomous and the part is framed).

This is in line with Aurnague's claim that “referential autonomy” is inversely proportional to their spatial character, and with Svorou's claim that the grammaticalization of semantic markers reflects their semantics (although Svorou's claim bears on the more global evolution which leads from parts, to locations in contact with parts, to regions extending from parts).

The evolution that leads from parts to regions will be taken up in the lecture on the evolution of spatial markers.

⁶ This observation was already made by Clark (1973 : 44).

I.3.3. RELATIVE FRAMES

The focus of this section is on the assignment of a front / back axis to unfeatured objects (i.e. to objects lacking intrinsic front and back). Relative left and right either follow from the type of projection used in assigning the front and back axis, or are marginal, and in some cases even absent (for ex. in Tzeltal).

I.3.3.1. THE ROUTE(S) FROM INTRINSIC TO RELATIVE FRAMES : THE CANONICAL ENCOUNTER (CLARK 1973)

According to Clark, the projection of intrinsic axes onto a non-oriented object takes its origin in the situation of *canonical encounter*. Note however the inversion of the L / R axis when we move from a canonical encounter to a “mirror reversal”.

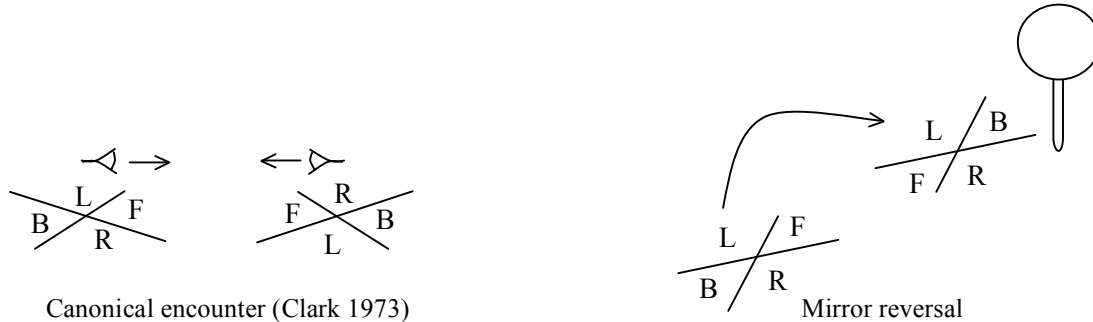

(However, there is a dialect of Tamil in which the full **rotation** of axes that is characteristic of the canonical encounter applies ; children occasionally use the canonical encounter with unfeatured Grounds ; Levinson 2003 : 86).

A number of languages (typically, languages that use absolute coding on a small spatial scale) restrict the projection of intrinsic axes to the F / B axis.

Vandeloise (1986) proposes that the assignment of L / R to non-oriented objects is modelled after interactional objects (e.g. a computer).

According to Vandeloise (1986, chap. 1), a *pragmatic bridge* would link intrinsic uses of *devant* to their relative construal, via the “functional” notion of perceptual accessibility.⁷

See pic. below : the wall is *in front of* (*devant*) the man and occludes the ball (implies that egocentric viewing has a key role) => what occludes something is in front of something.



I.3.3.2. TYPES OF PERSPECTIVES FOR INTRINSIC AND RELATIVE FRAMES: IN FRONT / BEHIND

Hausa, English and Tamil associate ‘behind’ with partly overlapping situations (‘F’ indicates the Figure) :

⁷ Vandeloise himself does not use *intrinsic* and *relative* (his own terms are, resp., *directional* and *functional*).

F indicates the Figure

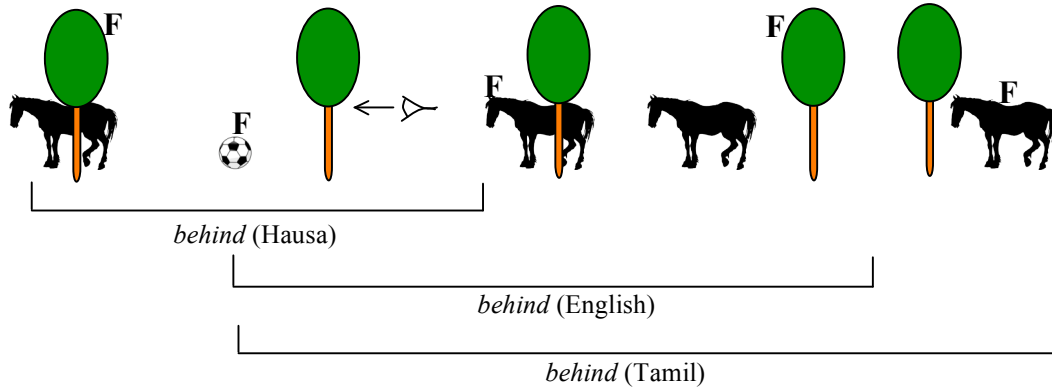

Two of the 5 uses of BEHIND illustrated above are intrinsic (situations 4 and 5). Pederson (2006) calls use 5 **ascribed intrinsic reference** (*behind* is construed as the converse of *in front*: *the tree is in front of the horse* \Leftrightarrow *the horse is behind the tree*). Ascribed intrinsic reference seems to be ruled out in English (and French). Hausa treats differently situations of occlusion and non-occlusion: when the horse is only partially occluded, it is described as being *in front of* the tree (and conversely, the tree as being *behind* the horse). The front-back axis of the viewer is translated to the tree and undergoes no reversal (unlike in English). This perspective is called **in-tandem** by Hill (1982, 1991). Other languages in which in tandem alignments for IN FRONT are found include Swahili, Turkana, Karimojong, Maasai (Heine 1989: 87). Surprisingly, Isma'il (1979) found that Afro-American speakers used the in-tandem perspective much more often than Euro-American speakers, and this observation was replicated by McKenna (in New York (1985). Hill suggests that the in-tandem perspective may have been transmitted from West Africa.

The situation of occlusion is special. When a Figure aligned with a Ground is occluded by it, the Figure is said to be *behind* the Ground (for ex. the ball above). This usage relies on the **mirror** (or face-to-face) perspective and is common to Hausa, English and Tamil.⁸ It follows that in Hausa the use of 'occlusive' *behind* relies on the mirror perspective, whereas the use of 'non occlusive' *behind* depends on the in-tandem perspective.

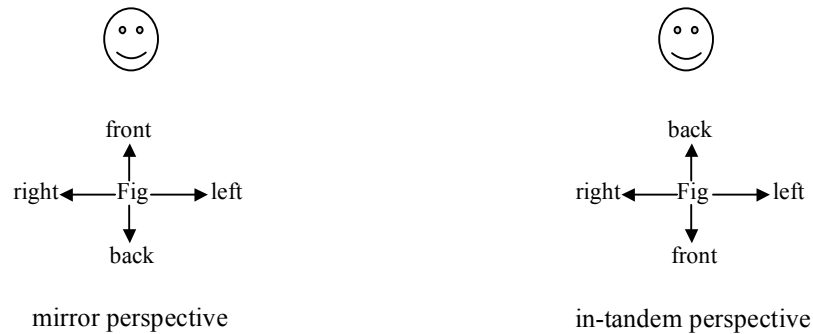

Hill notes that the in-tandem perspective prevails when objects move along the front / back axis (however a car is a kinetic object and has an intrinsic front anyway; a better example would be a red ball preceding a blue ball):

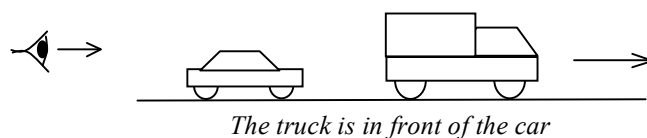

⁸ Herskovits uses the terms *encounter situation* / *coincidence situation* for the *mirror* / *in-tandem* perspectives resp.

Vandeloise speaks of a situation of **potential passing** : the object that comes first in the direction of movement is the first to pass by a landmark on the path ahead. In French, potential passing favors *avant* / *après* over *devant* / *derrière*, i.e. prepositions that also have a temporal use.⁹

1.3.3.3. CONCLUSION

There is cross-linguistic diversity in the extension of situations covered by relative uses of ‘in front of’ / ‘behind’. The occluding sense of ‘behind’ seems to be central (this is confirmed by acquisition data; Johnston 1985). There are three types of assignment of a relative front / back axis : **mirror reversal**, **translation** (in-tandem perspective), **rotation** with unfeatured or L/R symmetrical objects (could be rare, found in a dialect of Tamil).

⁹ Temporal uses of *devant* / *derrière* are familiar (*j’ai eu ma fille devant le garçon* ‘I had my daughter before the boy’ ; *il faut assurer derrière la livraison* ‘we have to be top-of-the-line once the goods have been delivered’, with *derrière* suggesting a notion of support, “backing up”, BF).

I.4. FRAMES OF REFERENCE AND COGNITION

In what ways do frames influence cognition? Can a dominant coordinate system exert an influence over the processing of spatial information even when no verbal response is expected? These issues have been investigated by Levinson and his collaborators (Pederson et al. 1998; Levinson et al. 2002). The results of this investigation and their interpretation gave rise to an attack on linguistic relativism launched by Li and Gleitman (2002). Further evidence for relativistic effects was gathered by Levinson et al. and is presented in Levinson (2003).

I.4.1. STUDIES ON “WHORFIAN” EFFECTS

Basic experimental design : subjects are shown an oriented display on a table, are rotated 180°, and must recognize or reproduce the previously seen display on another table (Pederson et al. 1998; Levinson 2003). 2 groups of subjects : presumed absolute coders, and subjects who should be relative coders.

Hyp. : responses, thought not verbal, should reflect the dominant frame of reference used in verbal interactions (a kind of “Whorfian” effect).

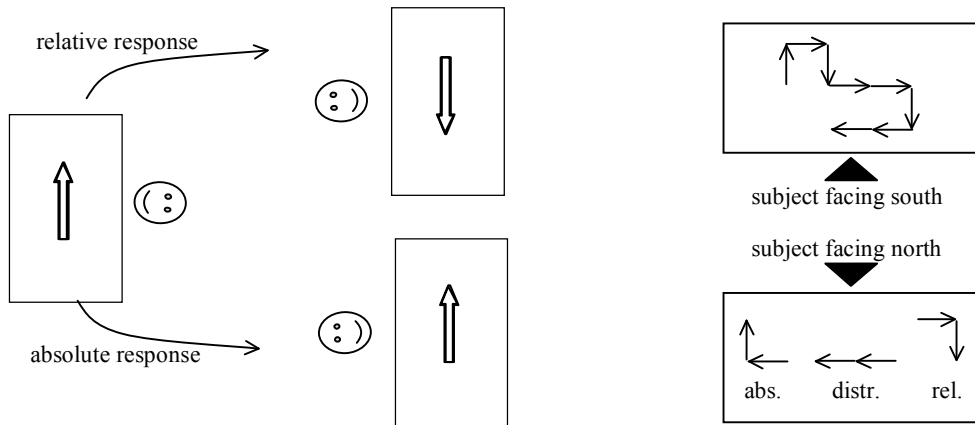

First subjects tested were speakers of Guugu Yimithirr (Australia) and Dutch. The oriented display consisted of 2 cards each with 2 colored chips (blue L of red, or blue R of red). Subjects had to choose a card on the first table and pick out the same card after having rotated 180° (recognition task). In another task, the oriented display consisted of a row of toy animals facing the same direction.

Another kind of task tapped “thinking” rather than mere recognition or recall : subjects had to complete a maze after rotation (see illust. above right). There was also a more taxing task in which subjects saw 2 objects A and B side by side, then B and C side by side on a second table, and had to place C w/r to A and B on the first table (“transitivity” task) :

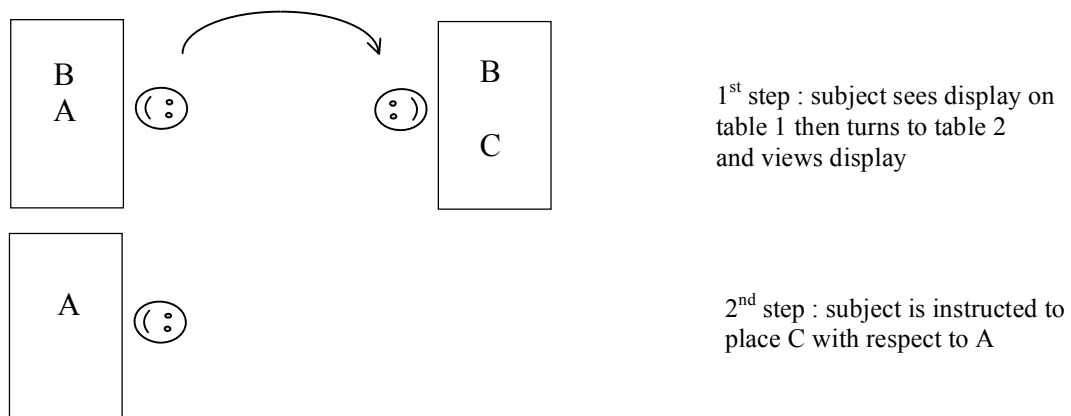

RESULTS



Results were clearcut for Dutch subjects : their responses were overwhelmingly relative. Speakers of Guugu Yimithirr (Australia) exhibited more mixed responses (i.e. there was a sizeable percentage of relative responses), but with a predominance of absolute ones.

Conclusion : GY speakers “not only speak a language that as a prerequisite requires storage and computation of orientation and absolute directions, they can also be shown when not engaged in speaking the language to think in a way that is concordant with it” (Levinson 2003 : 145).

These experiments were replicated with other languages (Tzeltal, Yukatek, Longgu, Arrernte) and confirm the correlation previously observed between linguistic coding and response, with another twist in the case of Tzeltal speakers, possibly a Whorfian effect again : when the transverse axis (underspecified, orthogonal to the downhill / uphill axis and oriented East / West) was used, subjects made more errors or were more inconsistent in the choice of the absolute vs relative frame (Pederson et al. 1998).

Note however a recall pattern independent of orientation (“monodirectional”) in the task in which subjects had to reproduce a row of toy animals, i.e. some subjects always aligned the toys in the same direction, whatever the orientation of the initial stimuli (Pederson et al. 1998 : 579).

The more taxing transitivity task is the one which produced a correlation between predominant linguistic coding and response in subjects where such correlation was otherwise non apparent (Tamil speakers; Levinson 2003 : 189). Using verbal recoding to facilitate processing can hardly be regarded as a Whorfian effect (it is just subvocal rehearsal).

Conclusion : “we must represent our spatial memories in a manner specific to the social normal means of expression” (Pederson et al. 1998)

I.4.2 ARE WHORFIAN EFFECTS SPURIOUS?

Li & Gleitman (2002) : objections and a non relativist proposal

The fact that absolute coders and relative coders had not been tested in the same conditions could explain the differences in their responses. Tzeltal speakers had been tested outdoors, in front of a large building, while Dutch speakers had been tested indoors. Would Dutch speakers turn into absolute coders if they were tested in an environment with salient landmarks?

Experiments of L & G show that when landmarks are visible, the number of subjects opting for the absolute solution increases dramatically (from 5% or less to 50%).

Id. with a very local landmark, an irrelevant toy placed on the stimulus table and on the recall table. When the landmark toy was placed on the recall table in the same relative position as on the stimulus table, recalls are relative. When the duck was placed in the same absolute position, recalls were absolute.

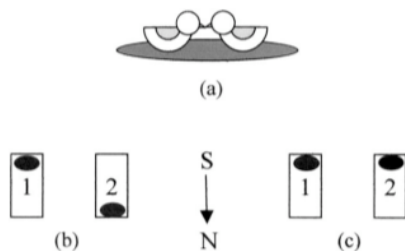

- (a) landmark toy (two ducks kissing on a pond)
- (b) relative condition (landmark toy in the same relative position before and after rotation)
- (c) absolute condition (landmark toy in the same absolute condition before and after rotation)

Comparison with rats (Tolman et al. 1946) : are rats in a maze relative learners or absolute learners?

Cf. Tolman et al.’s design : rats must learn to turn right (response-learners), other rats must learn a place.

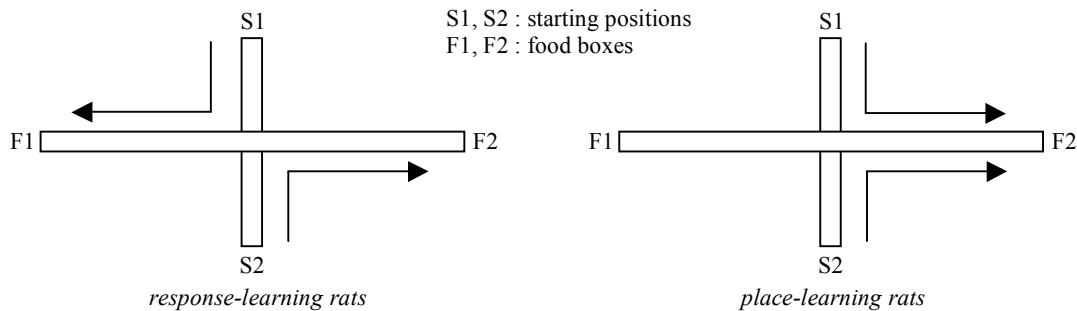

Now, rats are both response- and place-learners, depending on the cues (rich extra-maze cues favor place-learning)¹⁰. The point is that men should not display less flexibility than rats and are similarly opportunistic (i.e. use cues that are shared). Absolute coders belong to cohesive and insular groups who live in a familiar and mutually known environment. Conclusion “the causal engine both for the engrained spatial reasoning styles and the fashions of speech that we find in different communities may well be a derivative of their ambient spatial circumstances. Whatever these circumstances are, communities of humans will develop terminology to fit” (L & G : 290).

“Linguistic systems are merely the formal and expressive medium that speakers devise to describe their mental representations” (p. 290), for “linguistic categories and structures are more-or-less straightforward mappings from a preexisting conceptual space, programmed into our biological nature” (p. 266).

Levinson et al.’s counterattack

Objections to L & G raised by Levinson et al. (2002) :

- (1) instructions cued subjects to look for direction as an important aspect (whereas original instructions emphasized recalling the order of stimuli) ;
- (2) they used 3 animals in the to-be-recalled display, and 3 identical animals in the recall procedure, whereas Levinson et al.’s subjects had to choose from 4 animals; hence the task of Levinson et al. was more ambiguous (it could have been interpreted as about identifying animals correctly) and experimenters’ intentions were less transparent ;
- (3) L & G did not transfer their subjects to a distant place (they just used a swivel chair), with the result that subjects failed to see the other table as a different location, which would make intrinsic frame more salient ;
- (4) time before recall ap. L & G was so short that no memory recoding was necessary ;
- (5) L & G thought their experiment with a local landmark was about the possible intrusion of absolute coordinates, but this landmark had set up an intrinsic frame, not an absolute one¹¹ ;
- (6) The idea that absolute coding is found in small-scale communities sharing familiar landmarks “is not in accord with the ethnography (for example, our hunter-gatherer groups are far-flung wanderers, the Tenejapans [= Tzeltal speakers] do not live “in a village on a hill” but have a dispersed settlement pattern over a large territory), nor could it be determinative since there are lots of small, localized human groups who do not use absolute systems of spatial reckoning. But the main reason the hypothesis will not fly is that landmark cues do not play any special role in absolute systems like the Tzeltal or Arrernte systems. If you transport individuals from these communities out of their familiar territories, their ‘downhill’ or ‘north’ remains anchored to the same fixed bearing (in our compass degrees) that it always had” (Levinson et al. 2002 : 182).

Counter-experiment

2 tasks: animals-in-a-row task and maze-portion task : subjects must indicate where in a maze a toy man would end up if he had followed the path demonstrated by the experimenter on the first table (cf. illustration below). Two conditions, indoor and outdoor.

¹⁰ In Tolman’s original experiment, rats were found to be better place- than response-learners. This result contributed to establishing a cognitive theory of learning (by invoking the existence of cognitive maps) against a more behavioristic account. Posterior research showed that rats were sensitive to the differential availability of external cues.

¹¹ “What participants clearly did was use the large, bright objects [the duck pond] as an orientational cue – they were treating the whole assemblage, both duck ponds and animals, as one array to be reproduced. What kind of coordinate system is involved in maintaining the internal arrangements of an array while its orientation is varied? An orientation-free frame of reference of course – what we call an intrinsic frame of reference” (Levinson et al. 2002 : 173).

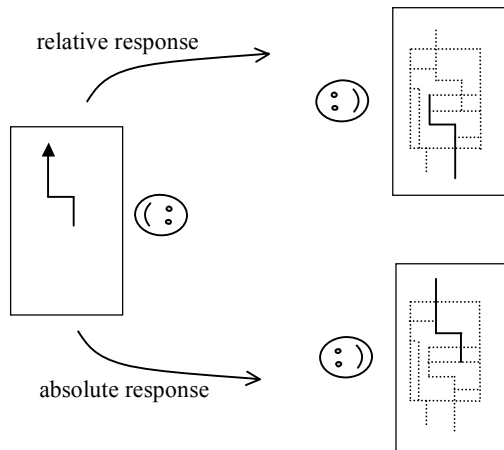

Results : no significant effect of outdoor vs indoor condition, for both tasks

Proportion of subjects using relative frame rises to nearly 100% in the maze task.

Results of L & G have not been replicated.

When the Animals-in-a-row task is made more difficult (by asking subjects to choose 3 animals out of 4, instead of supplying them with the correct animals from the outset), Dutch subjects should revert to their habitual operating mode, i.e. relative framing. This was indeed the case, and far less (4 times less) intrinsic (“absolute” ap. L & G) responses occurred this time.

Lastly, there is evidence for the fact that responses obtained by L & G in the duck pond condition were in fact intrinsic. Suppose the duck pond table is rotated 90° instead of 180°: if the duck pond were an absolute cue subjects should orient the display roughly parallel to the original display, i.e. no longer on a transverse axis but along a sagittal axis. This was indeed the case.

I.4.3. DEAD RECKONING

“Dead reckoning” is the updating of one’s own position with respect to one’s home base. For a speaker of a language heavily relying on an absolute frame, dead reckoning must be constantly operating, since one cannot give a route description without knowing at every moment where one is with respect to fixed bearings (for ex. *go north from here*).

EXPERIMENT

Speakers of Guugu Yimithirr (extensive use of an absolute frame based on cardinal directions, roughly N-S-W-E but skewed a few degrees clockwise, limited use of intrinsic frames and no use at all of any relative frame ; see Levinson 2003 : 115s).

Subjects were transported at varying distances from their home base and asked to point to a location (little familiar to them) 80 km away, with an open vista not exceeding 30 m.

Dutch speakers (members of a club of wild-mushrooms pickers) were asked, 5-10 km away from their car, to point to the car (they did not know they would be tested). Their performance was no better than chance (it is hypothesized they find their way back by retracing their steps, and that this engages an ability distinct from that needed for dead reckoning).

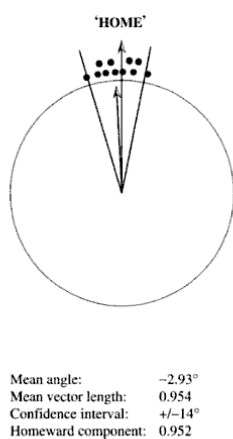
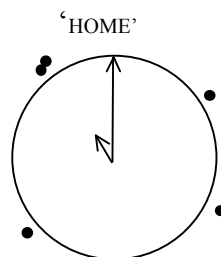

Figure 6.4. Guugu Yimithirr sample



Mean angle : 329.14°
 Mean vector length : 0.2585
 Confidence interval : n/a
 Homeward component : 0.222

Dutch sample

Each dot indicates multiple estimates by a single subject. The greater the spread of estimates, the shorter the vector ; the greater the angular errors, the larger the value of the angle. The homeward component is computed from the mean vector (it takes the value 1 when the angle between the mean angle and the expected direction is 0°).

I.4.4. GESTURES

Finally, Levinson et al. (Levinson 2003 : 244s) studied the gestures of “absolute” speakers and found them to be different from the gestures of “relative” speakers.

When recounting a story seen in a movie, absolute speakers produce absolute gestures, for ex., if the motion observed on the screen was from L to R, after rotation, they make a gesture from R to L (as if the path of the character were anchored with respect to the “real” world).

Gestures are made with partially or fully extended arms (by making the angle subtended by the arm more visible, the gesturer gives a clearer indication of the direction).

Absolute gesturers often exchange hands, i.e. often point with their left arm (presumably, again for the sake of greater clarity).

Gaze does not necessarily accompany gestures, probably because they do not replace themselves in a viewer-centered scene when indicating directions.

Relative gesturers differ from absolute gesturers on all these points (their gesturing space is relative, narrower, with one dominant hand and their line of gaze typically follows the direction of their arm).

I.4.5. CONCLUSION

Levinson (2003 : 302) : “Clearly, any language that forces a language-specific coding of events will require its speakers to remember those parameters at the time at which events are experienced. (...) And if a language lacks such a semantic parameter, there is good chance that the speakers of it fail to think in terms of those parameters too — as shown, for example, by the fact that English or Dutch speakers do not code spatial scenes in absolute coordinates.”

Now, the fact that speakers fail to consider some information needed for using a coordinate system does not mean that perception is bound to a particular coordinate system. Perception is plastic in the sense that speakers have the ability to process perceptual information in ways characteristic of distinct reference frames but fail to keep track of information that is needed for using a coordinate system.

In short, I argue for dissociating the cognitive ability for processing information in several reference frames (available) from keeping track of the information needed for operating in all coordinate systems. Dutch speakers do not keep track of absolute coordinates but it seems likely that they can function in absolute mode (why would an environmental landmark not function like the duck pond of Li & Gleitman’s experiment?).